

DS-500

Check Weighing/Portion Scale



- **Easy to use**
 - Perfect for Deli Applications for accurate weighing and portion control.
- **Large Customer Display**
 - Large figures LCD display
- **Compact Design**
 - Light-weight and compact design
- **Easy to clean**
 - Sanitary Stainless Steel Platter makes cleanup easy.
- **User Friendly Feature**
 - Auto power-off function saves battery energy.
- **DS-500 Scale Simple, Affordable, reliable!**

New Brunswick International, Inc.
DIGI Retail Scale and Labeling Systems



Stainless Steel Lid

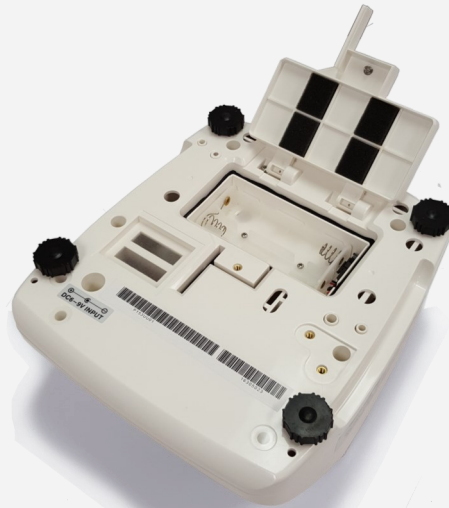

DS-500 Scale
Battery Opening
For 4 C Size
Dry Batteries



Scale Dimensions (30 lb)

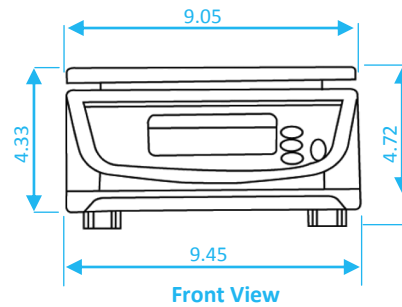

Front View

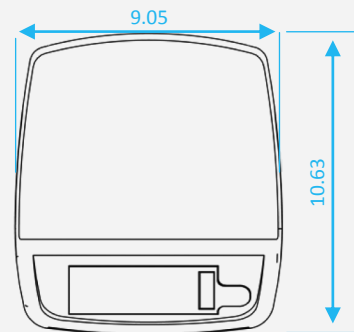

Top View

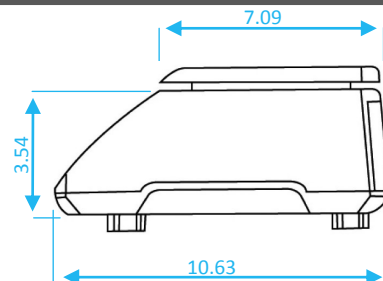

Side View

Units in Inches

Specifications

General	Power source	AC: Adapter (DC 5V~ 12V, 100mA) DC: Battery (4 C size dry batteries) or AC/DC
	Power Consumption	AC: 0.04W when DC 6V, or
	Operation humidity	15% - 85% RH Non-Condensation
	Operating Temperature	-10°C ~ +40°C
	Operator Display	High Contrast LCD 5 digits (Weight)
	Net Weight	2.2kg (with Battery)
	Display Designators	Zero, Net, Battery
Dimensions	Capacity	30lb
	Weighing Interval	Single x 0.01
	Platter Dimensions	9"(W) x 7"(D) x 1/2"(H)
	Overall Dimensions	9"(W) x 9.5"(D) x 4.5"(H)



New Brunswick International, Inc.

Corporate Headquarters
76 Veronica Ave
Somerset, NJ 08873
TEL: (732) 828-3633
FAX: (732) 828-4884

West Coast Office
530 West Central Ave. Suite C
Brea, CA 92821
TEL: (714) 671-7911
Fax: (714) 671-0798

www.nbidigi.com

